

# ECE 3274 Lab 1 (Intro)

## Forward (DO NOT TURN IN)

The purpose of this lab course is to familiarize you with high-end lab equipment, and train you in its operation. Many of these labs may be similar to labs you have completed in your Lab-In-A-Box courses. The main difference between these two courses is the equipment you will use to perform measurements. These skills are invaluable to both EEs and CPEs.

Labs will often be framed as if you are a full time engineer working in industry. Please attempt to complete these experiments as you would work for an employer. Pre labs are background information and the information required to complete the labs is not presented in any course materials. You are expected to use internet search engines, equipment manuals, online resources, and your colleagues to find appropriate answers to pre lab questions. Pre labs are short answer conceptual questions, long form mathematical solutions are not required.

You are expected to use engineering exponents for all answers (p,n,μ,m, N/A, k, M, G) and to give each with a precision between one and three leading digits and zero to one decimal place.

EX: 20.1 mA, 10.1 MHz, 1.0 V, 220 μF

Your calculator will have a setting that will automatically generate the correct format.

The lab uses 10% resistor values at 5% tolerance. Use only 10% resistor values with multipliers between 10 Ω and 1 MΩ for any calculation. These are the values available in the lab:

10	12	15	18	22	27	33	39	47	56	68	82
----	----	----	----	----	----	----	----	----	----	----	----

## Lab 1 Summary

The purpose of this first lab procedure is to introduce you to the equipment in the lab. Please complete the pre lab before arrival. This lab has six main learning objectives. At the end of this lab you should be able to:

1. Use best practices for connecting equipment to other equipment or a Device Under Test (DUT)
2. Manually operate the Digital Power Supplies
3. Manually operate the benchtop Digital Multi-Meters (DMM)
4. Manually operate the Arbitrary Signal Generator
5. Compensate and use a 10X probe
6. Manually operate the Digital Oscilloscope and perform a basic scope capture using the Signal Express software
  - a. **We must use the signal express software to perform scope captures due to cyber security vulnerabilities in the oscilloscopes to USB based viruses.**

We will perform a series of measurements designed to ensure you are able to operate the lab equipment listed above.

- The TA will demonstrate how to connect banana plugs, BNC cables, and how to compensate a probe.
- We will set the bipolar channels of the DC power supply in constant voltage mode and measure this voltages using two DMMs.
- We will perform two and four wire resistance measurements of two resistors.
- We will then create a simple division network using two resistors. This network will familiarize you with the internal construction of an attenuating probe, although our probe will be a roughly 2X probe vs a 10X probe due to our resistor limitations.
- We will then adjust the power supply into constant current mode and observe the voltage change.
- We will measure this current directly with a DMM.
- We will use a attenuating oscilloscope probe to measure the same signal
- We will use the function generator to create an AC wave and measure the RMS value of the amplitude
- We will measure this AC wave with the oscilloscope using a BNC cable to connect the two instruments
- We will adjust the trigger settings on the oscilloscope to properly acquire the signal
- We will capture this waveform using the signal express software

This area left blank to enable double sided printing

## **Pre Lab ( TURN IN 1 PER PERSON AT BEGINNING OF LAB)**

Name: \_\_\_\_\_ Day and Time: \_\_\_\_\_

CRN: \_\_\_\_\_

Please complete the following short answer questions. Use whatever resources you feel are required to locate the information needed to answer the questions. Use basic schematics / diagrams or simple equations.

1. What is a 10x probe? Draw a simple schematic of a 10x probe below (5 Pts):
2. Why is a 10x probe used? What is an advantage? What is a disadvantage (5 Pts)?
3. When connecting a scope probe where does the clip connection connect to in the scope? What is its purpose (5 Pts)?
4. What is a scope trigger, why is it used (5 Pts)?
5. How do you change the trigger settings on a scope (5 Pts)?
6. A scope can be AC or DC coupled. Draw a simple schematic of a circuit that would ac couple the signal (5 Pts):
7. What is the purpose of DC or AC coupling (5 Pts)?

8. What is a BNC cable? When would you use a BNC cable vs a 10x probe (5 Pts)?
  
9. What is the purpose of a sync output on a function generator (2.5 Pts)?
  
10. Where should the sync output be connected to properly use it (2.5 Pts)?
  
11. What is a 4 wire resistance measurement? Why would you use one? How do you switch between 2 and 4 wire mode on the DMMs present in the lab? Draw a schematic of a resistance measurement for 2 and 4 wire measurement (5 Pts):
  
12. Draw a schematic of a multi-meter measuring current. Include the circuit inside the DMM that allows the ADC that measures voltage to measure current (5 pts).

13. Using the following picture as a reference, connect the ports you would use on the meter to the circuit component being measured in the table below (20 Pts):

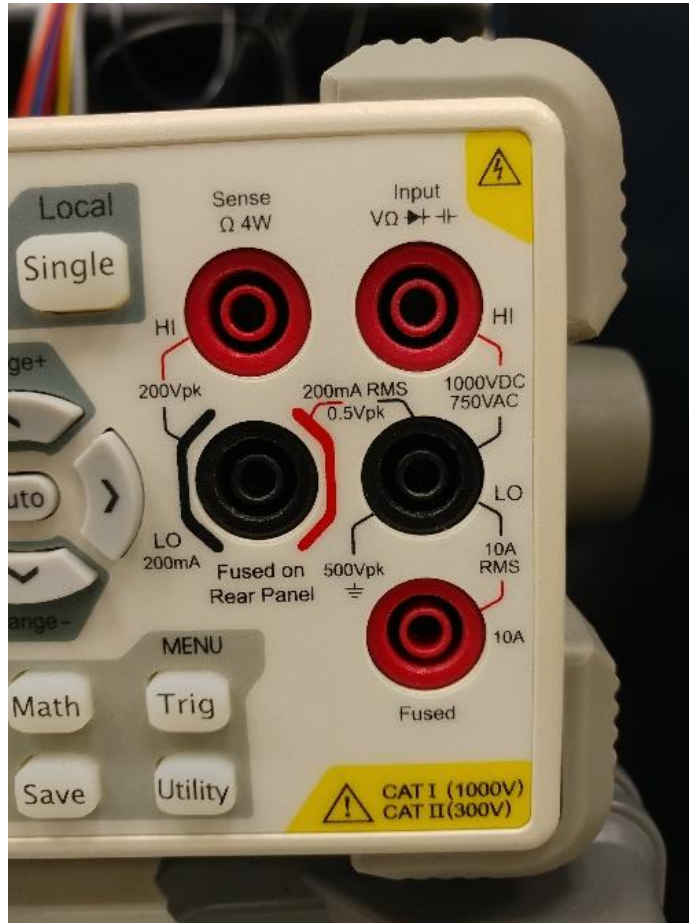

Voltage (AC or DC)	Low Current ( $I < 200 \text{ mA}$ )	High Current ( $I > 200 \text{ mA}$ )	2 Wire Resistance	4 Wire Resistance

14. What happens if you exceed the current limit on a multi meter (5 Pts)?

15. What is the current limit on a power supply? How would you set the current limit? Why would you set the current limit (5 Pts)?

16. What is a floating instrument or supply? Name two instruments in the lab that are not floating (5 Pts):

## Lab Procedure (DO NOT TURN IN)

### *Required Equipment*

First select two BNC-BNC cables. These are black coaxial cables available on the wall in the lab. They have locking connectors on each end and are pictured below:



Also select a 10X attenuating scope probe. These probes have a retractable J-hook and a ground clip on one end, and a specialized BNC connector on the other end. See the picture below:



Also select four banana plug cables. It is recommended you use two red cables and two black cables for this lab.

## **Setup**

Power on the DMMs, function generator, oscilloscope, and power supplies present at your bench. Begin by ensuring your power supply's maximum current range on the blue and purple channels (2 and 3) is set to no more than 200 mA.

***(DMMs have a power switch on the back that may be off!)***

## **DC Generation and Measurement**

### **Constant Voltage Power Supply Operation**

Connect channel 2 of one of your power supplies to the voltage measurement ports on the lower left multi meter. Select DC voltage measurement mode on the DMM. Select a voltage of 5 V and activate the channel 2 output. Record your voltage on the provided datasheet.

Connect channel 3 of the Power Supply to the lower right DMM's voltage port. Select a voltage of 5 and enable channel 3 output. Record the voltage.

***NOTE: Channel 2 and 3 share a single common port. You must use this common port as the negative terminal for each of these measurements.***

Turn your supply's outputs off. Disconnect your DMMs from your supply.

### **Division network**

Retrieve a 820  $\Omega$  resistor and a 1.8 k $\Omega$  resistor from the drawers. Measure the resistance of each resistor using the two wire mode on a DMM. Use alligator clip adapters to make this measurement easier. Record these measurements.

Now activate the 4 wire mode for resistance measurement on the DMM by pressing the resistance measurement button a second time. Connect each resistor one at a time in a 4 wire measurement configuration and measure the resistance.

***NOTE: This is also called a kelvin measurement.***

Now place the two resistors in the bread board provided at your bench. Use jumper wires to connect the binding posts to the appropriate bread board locations. Connect channel 2 of your power supply to the binding posts.

Create a series circuit of the 10 k $\Omega$  and 1 k $\Omega$  resistors, with the larger resistor first.

Connect the negative terminal of the Lower Right DMM voltage measurement mode to the common terminal of the power supply directly to reduce clutter on the breadboard. Connect the positive terminal to the node shared between the two resistors.



Connect the positive terminal of the Lower Left DMM to the positive output of the supply and the negative terminal to the common terminal of the supply.

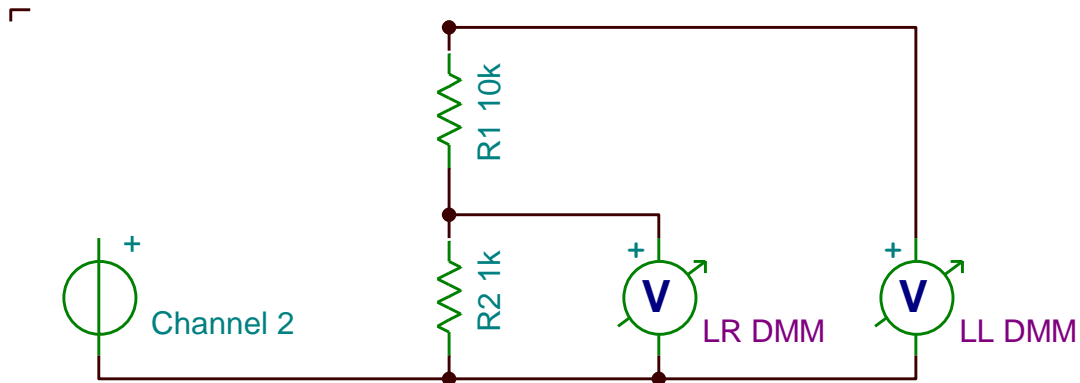

Set the supply to 10 V and enable the output. Record the voltage measurements from each DMM. Divide the two and obtain a rough estimate of the attenuation of the network.

Turn off the output of your supply and remove the 10 k $\Omega$  resistor from the circuit.

### DC Current Measurement

Remove the positive terminal of channel 2 from your breadboard. Connect the Lower left DMM in series with the power supply in current measurement mode, set up for a **high current**.

**DO NOT USE THE 200mA range on the DMM. If your circuit is not wired correctly you may blow the fuse.**

Connect the output of the current meter to the breadboard and then to the 1 k $\Omega$  resistor.

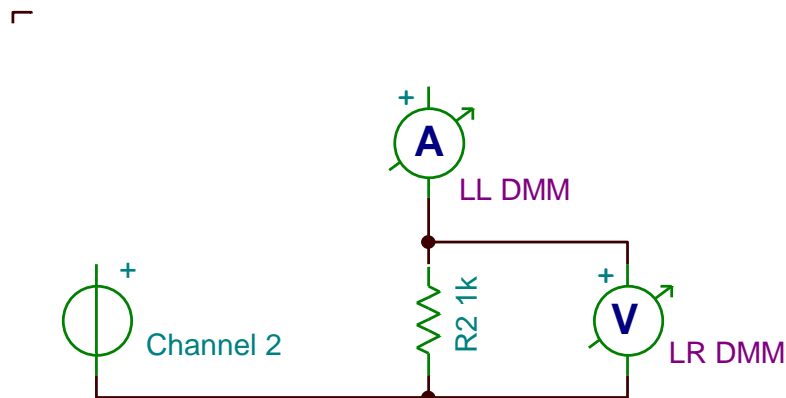

Turn the supply on. Observe and record the current on the Lower Left DMM. Observe and record the voltage on the lower right DMM.

Calculate the value of  $R_2$ . Determine how much power is dissipated in  $R_2$ .

Select the current limit on channel 2. Lower the current limit to 2 mA below the current measured in the previous step. Record the current and voltage measurements from the multi meters. What do you notice about the voltage? What about the current?

Increase the voltage on the supply without increasing the current limit. What do you observe?

### **Scope Measurement**

Use your 10X probe to measure the voltage of the power supply using the oscilloscope on channel 1. Connect the ground clip to the lower potential terminal of the resistor. Connect the probe tip to the higher potential terminal. Ensure your scope is set to DC coupling and 10X attenuation.

Adjust the vertical scale and add an amplitude measurement to the oscilloscope using the measurement key. Record this measurement.

Change the coupling to AC coupling. What happens?

Disconnect the power supply, probe, and DMMs from the circuit.

### ***AC Generation and Measurement***

#### **Probe compensation**

Connect your probe to the probe compensation output on the lower right hand side of the scope. Connect the ground clip to the ground connector. Press the auto set button on the scope. Observe the waveform. What type of wave is it? Are the edges rounded? If the edges are rounded ask your TA to help you compensate the probe.

#### **Function Generator**

Retrieve a BNC-T adapter, and a BNC to female Banana plug adapter. Connect the banana plug adapter to the BNC-T and connect a BNC cable to the other end. Connect the T junction to the output port of channel 1 on the function generator. Connect the Banana plug adapter to the voltage port on the lower left DMM using banana plug cables. Connect the BNC cable to channel 1 on the scope.

Set the DMM to AC voltage measurement mode. Set the Function generator to create a  $5 V_{\text{peak-peak}}$  1 kHz sine wave. Set the output mode to High-Z (high impedance). Observe the voltage value from the DMM. Does the measured voltage differ from the set voltage? Why or why not?

Auto set your scope. Adjust the waveform time scale and amplitude to fill the screen with 1-2 cycles of the sine wave. Ensure channel 1 is set to AC coupling and 1x attenuation.

Observe the waveform. Remove any measurements and add a measurement for frequency and for  $V_{pp}$ . Record these measurements. Adjust the trigger level up and down. What happens? Adjust the DC offset on the generator up and down. What happens?

Now connect the Sync output from channel 1 to channel 2 of the scope. Enable channel 2. What does the waveform look like? Change the frequency up and down on the generator. What do you observe on channel 1 and channel 2? Change the trigger to trigger on channel 2. Now change the DC offset on the generator. What happens to the signal displayed on channel 1?

Remove the cable from channel two of the oscilloscope and insert it into the AUX input on the scope. Modify the trigger settings to trigger on the AUX input, you may need to push the trigger knob into the scope. What purpose would this input serve?

Reconnect the sync output to channel 2. Open the Basic Scope Capture signal express project.

Are you using 10X probes? Set your probe attenuation on channel 1 and channel 2 using signal express to the correct attenuation.

Set the voltage range on channel 1 and channel 2 to 10 volts.

Click run continuously.

Adjust your record length to achieve a similar picture to what you manually set on the scope.

Open the trigger tab on the signal express project. Set the trigger type to EDGE on channel 1. What happens?

In the project documentation drag channel one and channel two onto the documentation. Hide any legend by right clicking and hiding it. Export the project to HTML and save the exported file on a flash drive. Print this plot out on the lab printer.

Clean up your lab bench, return all components, cables, and adapters, and power off all instruments.

This area left blank to enable double sided printing

# Lab Data Sheet (TURN IN 1 PER GROUP)

Name: \_\_\_\_\_

TA: \_\_\_\_\_

Name: \_\_\_\_\_

Day and Time: \_\_\_\_\_

CRN: \_\_\_\_\_

Bench: \_\_\_\_\_

## ***Constant Voltage Power Supply Operation***

Channel 2 Voltage: \_\_\_\_\_ (2.5 points)

Channel 3 Voltage: \_\_\_\_\_ (2.5 points)

## ***Division Network***

Fill in this table (5 pts):

Nominal Resistance	2 – Wire Measured	4 – Wire Measured	Difference
820 $\Omega$			
1.8 k $\Omega$			

Calculated Attenuation: \_\_\_\_\_ (2.5 points)

LL DMM Voltage: \_\_\_\_\_ (2.5 points)

LR DMM Voltage: \_\_\_\_\_ (2.5 points)

LL / LR Voltage: \_\_\_\_\_ (2.5 points)

## ***DC Current Measurement***

LL DMM: \_\_\_\_\_ (2.5 points)

LR DMM: \_\_\_\_\_ (2.5 points)

R<sub>2</sub> Resistance: \_\_\_\_\_ (2.5 points)

R<sub>2</sub> Power: \_\_\_\_\_ (2.5 points)

Change the current range (5 points):

LL DMM: \_\_\_\_\_

LR DMM: \_\_\_\_\_

What do you observe when changing the voltage (2.5 points)?

## ***Scope Measurement***

Measured DC value: \_\_\_\_\_ (2.5 points)

What happens when changing the coupling (2.5 points)?

### ***Probe Compensation***

What type of wave does the probe compensation generate? (2.5 points)

Is your probe compensated? What does compensation adjust for? (2.5 points)

### ***Function Generator:***

DMM Voltage: \_\_\_\_\_ (2.5 points)

Comments (5 points):

Oscilloscope Measurements:

Frequency: \_\_\_\_\_ (2.5 points)

Amplitude: \_\_\_\_\_ (2.5 points)

Change trigger and observe (2.5 points):

Change offset and observe (2.5 points):

What does the sync output look like? How does it change with channel 1? (5 points)

How does changing the trigger two channel two affect the how the signal changed when adjusted? (5 points)

What purpose does the AUX input serve as a trigger? Why is there a sync output on the generator? (5 points)

Are you using 10X probes to capture the signal from the generator? (10 pts)

Attach a scope capture with 2-5 cycles shown and no clipping (10 pts):